

Pump specifications:

Type.....	BA150E D285
Max. flow	475 m ³ /hour (2091 US GPM)
Max. pressure	35 mwc (115 ft.)
Connections.....	DN150 (6")
Solids handling	80 mm (3,15")
Impeller type	Semi-open impeller
Priming system	BBA MP50
Engine	Perkins 404D-22T
Emission standard	Stage IIIA
Frame	BF10-23
Dry weight.....	Approx. 1400 kg (3080 lbs.)

FEATURES

BA auto prime pump

The BA range of pumps has been designed with a clear focus on reliability, efficiency and durability. Featuring a 100% mechanical priming system, the BA series pumps quickly prime and re-prime, even from dry conditions. The heavy build style of both pump and canopy make the BA range perfect for use in the strenuous contractor market.

World-class performance

The BA range is built to be deployed on the most demanding dewatering and sewage bypassing applications. Using high efficiency pumps and state-of-the-art diesel engines, the pumps offer maximum performance at minimal cost, fully in-sync with the company philosophy of "Lowest cost of ownership".

Sustainability

- High efficiency pumps minimising fuel consumption
- Corrosion free hot dip galvanized frame
- Corrosion free composite grill panel
- 100% Oil-spill free priming system

Complete package designed & built by BBA Pumps

- Complete in-house design & production
- Over 60 years of experience in the market
- Extensive testing facility in-house
- Contemporary & functional design
- Durable & eco-friendly materials
- Custom builds available

After sales service & product support

- Single supplier for parts, spares & accessories
- Dedicated customer help-desk (24h service)
- Dedicated service department in-house
- Global parts distribution network
- Optional global on-site servicing
- Extensive training options available (technical & commercial), on-site or in-house

PERFORMANCE CURVES (1750 RPM)

Continuous duty according ISO 9906

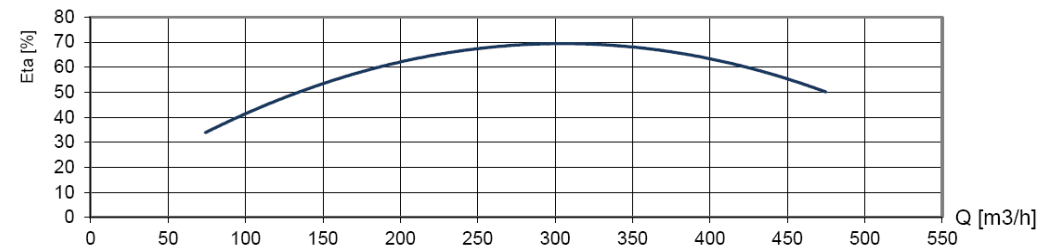
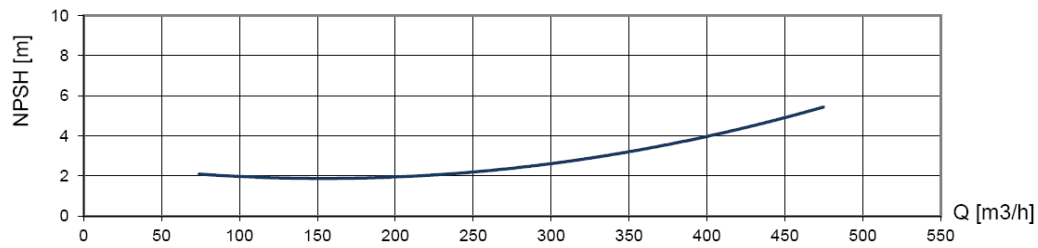
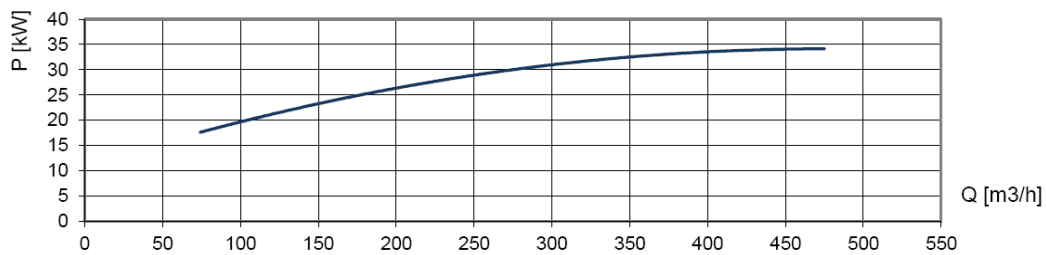
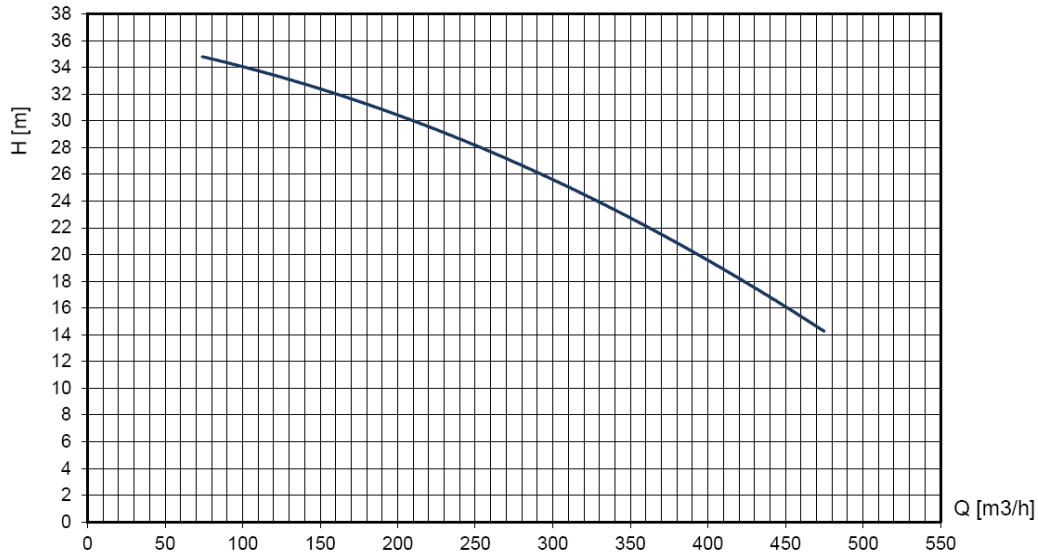

Engine speed rpm	H mwc	Capacity Q in m ³ /h				Fuel consumption (BEP) l/h
		150	250	350	450	
1750		32	28	23	16	9
1700		29	25	20	14	8
1600		25	21	16	10	7
1500		22	18	13	6	6

STANDARD TECHNICAL SPECIFICATIONS

BBA auto prime pump

Pump type.....BA150E D285
 Max. flow.....475 m³/hour (2090 US GPM)
 Max. head.....35 mwc (115 feet)
 Impeller type.....Semi open impeller
 Solids handling.....80 mm (3.15 inch)
 Pump casing.....Cast iron GG20
 Impeller.....Chrome Moly 42CrM04
 Self-cleaning wear plate.....Chrome Moly 42CrM04 (cutter slots)
 Pump shaft.....C45
 Shaft seal.....Mechanical seal
 Seal faces.....Tung/Sic
 Seal rubbers.....Viton



BBA priming system

Pump type.....BBA MP50 Diaphragm pump
 Air handling capacity.....50 m³/h (30 CFM)
 Max. vacuum.....8.5 m (29 inHg)
 Drive.....Toothed belt (continuous drive)
 Float box.....Aluminium
 Non return valve.....Cast iron GG25
 Check valve disc.....Buna-N

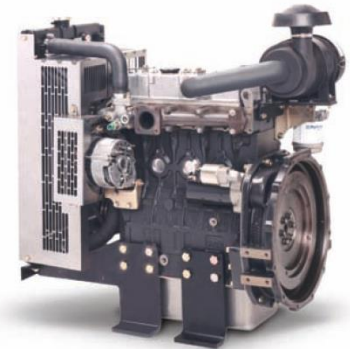

Engine

Engine brand.....Perkins
 Engine type.....404D-22T
 Flywheel power.....36 kW (49 Hp)
 Max. engine speed.....1500 – 1750 RPM
 Fuel consumption.....237 g/kWh
 Displacement.....2.2 l
 Number of cylinders.....4
 Cooling system.....Water cooled
 Emission standards.....Stage IIIA – Tier 4i equivalent

BBA dashboard LC20

- Auto start/stop system
- Two float switches included (10m cable)
- Switch Manual-0-Auto
- Tachometer
- Hour counter
- Warning lights “oil and engine temperature”
- Warning light “auto stand-by”



Fuel system

- PE fuel tank 140 L. net (36 US Gallon)
- Fuel tank cap Ø 60 mm
- Mechanical fuel injection system
- Fitted with water separator & extra in-line fuel filter

Electrical system & safety features

- Nominal voltage 12 Volt
- Premium quality battery
- Low oil pressure shut down
- High temperature shut down

FRAME BF10-23

BBA open diesel unit

Frame model.....	BF10-23
Dimensions L x W x H	Approx. 2270 x 1040 x 1340 mm (without connections)
Dimensions L x W x H	Approx. 89 x 41 x 53 inch (without connections)
Basic frame	Hot dip galvanised
Panel.....	Composite grill panel
Fuel tank	Composite tank net 140 ltr (36 US Gallon)
Fuel tank autonomy	15 hours (at 1750 rpm BEP)
Fuel tank cap	60 mm (2.5 inch)
Forklift pockets.....	Fitted with 2 forklift pockets
Lifting point	Fitted with single lifting point
Connections	Please consult "auxiliary items"
Exhaust system	Exhaust is mounted on the engine
Radiator box	Genuine Perkins
Documentation box.....	BBA user manual and warranty book

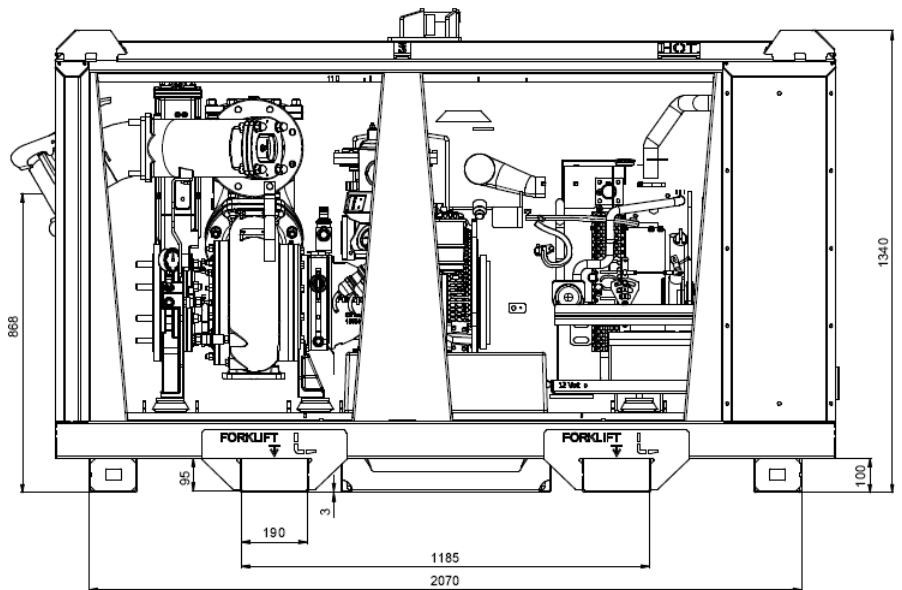
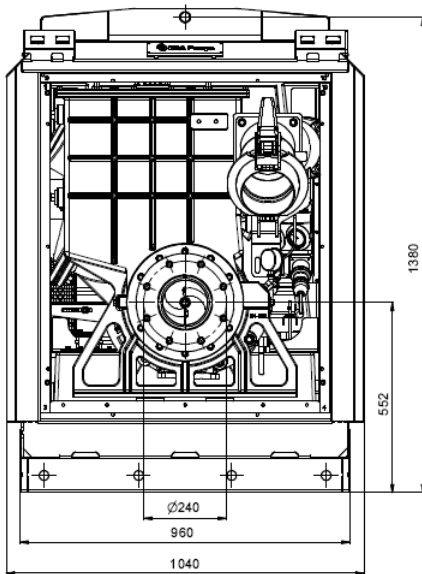

Actual dimensions (in mm) may vary depending on selected quick couplings.



Semi-open impeller
Corrosion and abrasion resistant Chrome Moly (42CrM04) alloy.



Priming system
Diaphragm pump, air-cooled, water-resistant and oil-spillage free. Air capacity of 50 m³ per hour.



Easy inspection
Oil glasses, drain valves and fill plugs are all easily accessible.



Fuel tank
Corrosion-free, 140 litre, high-density polyethylene (HDPE) fuel tank, located in base of frame.

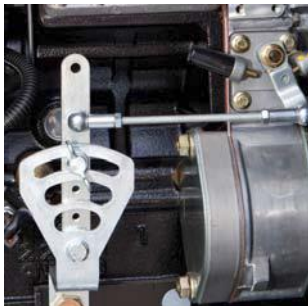

Speed control
Variable speed control between 1500 rpm. and 1750 rpm.



Large inspection covers
Easy access to float box, impeller and non-return valve.



4 Year limited warranty
The BBA limited warranty covers years or operating hours whichever occurs first. For more details please consult the BBA warranty book.



User Manual BA series
Extensive user manual with important information concerning the pump unit, pump installation and safety warnings. Available in several languages.

Pictures used are for illustration purposes only.

AUXILIARY ITEMS
Site Trailer Kit

3031720310	Trailer Kit	
	Off-road design	
	Towbar is height-adjustable	
	Not permitted on public road	
	M10-23 / ET10-23 / BF10-23	

Discharge connections

Art.nr.		Ø inch	Ø mm	Connection	
5080873	30°	6	150	Flange K240	
1516604209	30°	8	200	Flange K295	
5080876	30° female (cup)	6	150	System B	
5080881	30° male (ball/lever)	6	150	System B	
5080877	30° male (ball)	6	150	System C	
5080882	30° female (cup/lever)	6	150	System C	

Suction connections

Art.nr.		Ø inch	Ø mm	Connection	
5080884	30°	6	150	Flange K240	
1516604208	30°	8	200	Flange K295	
5080889	30° female (cup)	6	150	System B	
5080890	30° male (ball/lever)	6	150	System B	
5080887	30° male (ball)	6	150	System C	
5080888	30° female (cup/lever)	6	150	System C	

Suction hose with strainer L=5 metre

Art.nr.	Ø inch	Ø mm	Connection	
7047054	6	150	Flange K240	
7047057	8	200	Flange K295	
7047007	6	150	System B male (ball/lever)	
7047037	6	150	System C female (cup/lever)	

Suction hose with strainer L=6 metre

Art.nr.	Ø inch	Ø mm	Connection	
7047055	6	150	Flange K240	
7047058	8	200	Flange K295	
7047008	6	150	System B male (ball/lever)	
7047038	6	150	System C female (cup/lever)	

Recommended suction pipe (maximum velocity = 4 m/sec)

M3/H	US gallons	FLOW (L/sec)	4"	5"	6"	8"	10"	12"
			100	125	150	200	250	300
252	1110	70	8.91	5.70	3.96	2.23	1.43	0.99
288	1268	80	10.19	6.52	4.53	2.55	1.63	1.13
324	1427	90	11.46	7.33	5.09	2.86	1.83	1.27
360	1585	100	12.73	8.15	5.66	3.18	2.04	1.41
403	1775	112	14.26	9.13	6.34	3.57	2.28	1.58
432	1902	120	15.28	9.78	6.79	3.82	2.44	1.70
468	2061	130	16.55	10.59	7.36	4.14	2.65	1.84
504	2219	140	17.83	11.41	7.92	4.46	2.85	1.98