

PRORIL

50 Hz

GOVOX-M Series, these vortex pumps are equipped with an agitator, which forcibly agitate the fluid for easy and efficient transmission of sludge, sand, mud, and debris.

Sewage Pump

GOVOX 337-U

Vortex and Agitator Pump



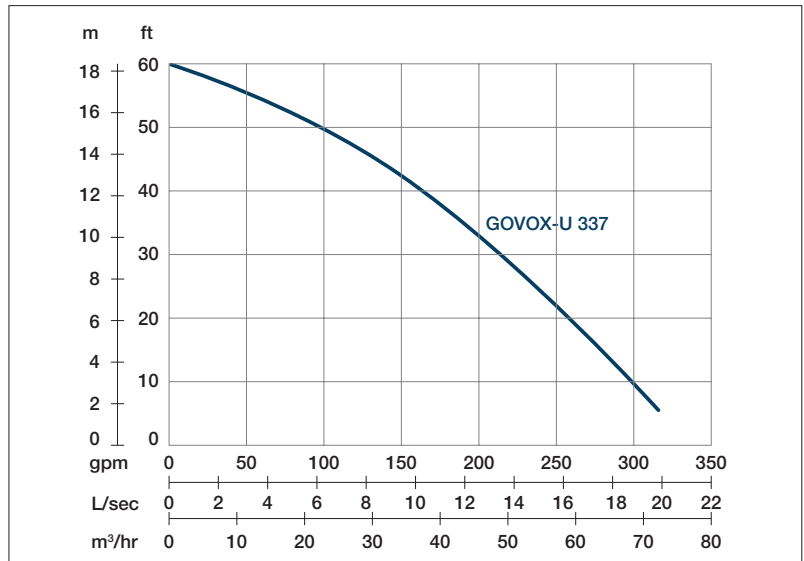

Shaft Speed : 2850 rpm

Outlet : 80mm, 3in

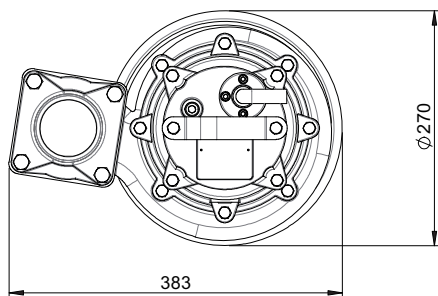

OUTPUT	HEAD	FLOW
3.7 kW	Rated : 15m, 49ft	Rated : 8 l/s, 132 gpm
5 HP	Max : 22m, 72ft	Max : 18 l/s, 277 gpm

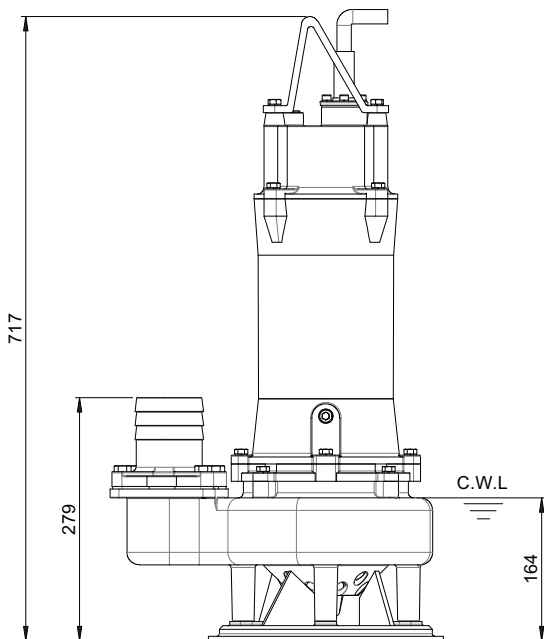

Weight : 53kg / 117 lbs

Pump Type	Electric Submersible Pumps	
	3-Phase	
Motor	Type	Induction Motor
	Poles	2 Pole
	Insulation	Class F
	Protector	Circle Thermal Protector
	Starter	D.O.L.
Lubricant	Food Grade (ISO VG32)	
Impeller Type	Vortex	
Shaft Seal	Double Mechanical Seal	
	Silicon Carbide VS Ceramic / Carbon	
Bearings	C3 Shielded ball bearings	
Cable	H07RNF	
	Length: 10m (33ft) or longer upon request.	
Materials	Pump Casing	Gray Iron
	Impeller	Gray Iron
	Motor Frame	Gray Iron
	Motor Shaft	Stainless Steel
	Agitator	Ductile Iron
Max. Liquid Temperature	104°F (40°C)	
Max. Submersion Depth	66ft (20m)	
pH Range	pH 5 - pH 8	