

PRORIL

50 Hz

GOVOX Series, these vortex pumps feature a less impeller wear and longer pump life by a vortex flow that allows fibrous materials and solid matters to be pumped out without obstruction.

Sewage Pump

GOVOX 475U

Vortex Pump



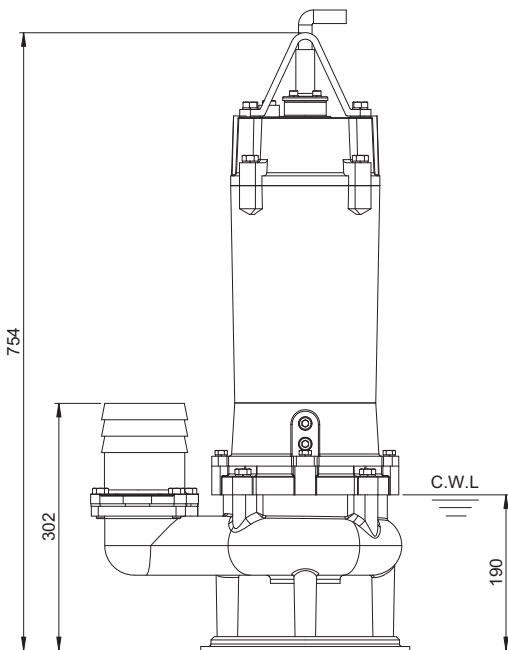
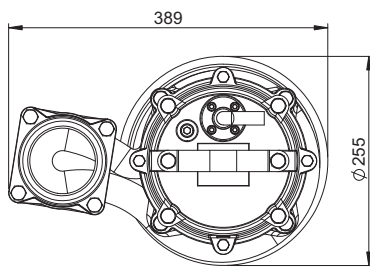

Weight : 67kg / 147.4lbs

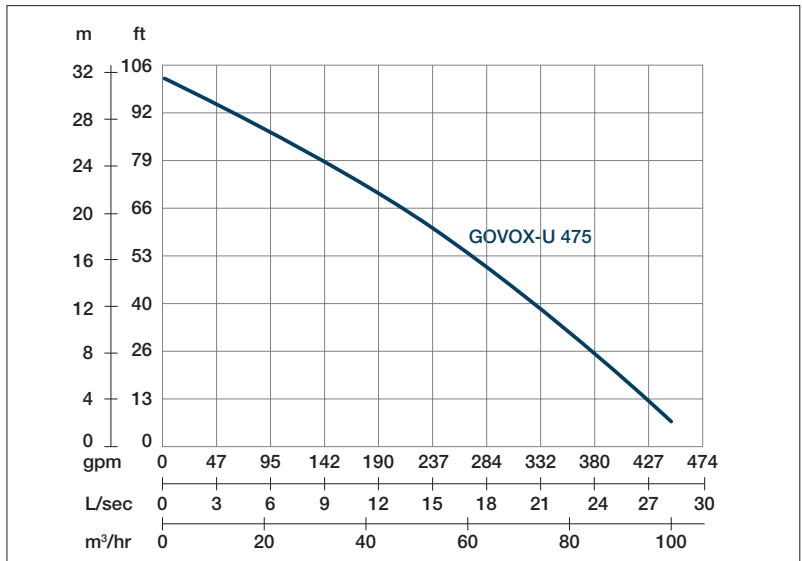

Shaft Speed : 2850 rpm

Outlet : 100mm, 4"

OUTPUT	HEAD	FLOW
7.5 kW	Rated : 20m, 66ft	Rated : 12.5 l/s, 198gpm
10 HP	Max : 31m, 102ft	Max : 28.3 l/s, 449 gpm

Pump Type	Electric Submersible Pumps	
	Three Phase	
	IP 68	
Motor	Type	Induction Motor
	Poles	2 Pole
	Insulation	Class F
	Protector	Circle Thermal Protector
	Starter Method	D.O.L.
Lubricant	Food Grade (ISO VG32)	
Impeller Type	Vortex	
Shaft Seal	Double Mechanical Seal	
	Silicon Carbide VS Ceramic / Carbon	
Bearings	C3 Shielded ball bearings	
Cable	H07RNF	
	Length: 10m (33ft) or longer upon request.	
Materials	Pump Casing	Ductile Iron
	Impeller	Gray Iron
	Motor Frame	Gray Iron
	Motor Shaft	Stainless Steel
Max. Liquid Temperature	40°C (104°F)	
Max. Submersion Depth	20m (66ft)	
pH Range	5-8	