

po-Söffel A-H

Fields of application:

The drainage pump **po-Söffel A-H** is a submersible centrifugal pump for delivery of clean or dirty water with solid admixtures up to a particle size of 7 mm.

Technical data:

Delivery rate range	120 - 0 m ³ /h
Delivery head range	0 - 60 m
Medium temperature	max. 40 °C
Immersion depth	max. 20 m
Density	1100 kg/m ³
pH-value	4-8
Current type	three-phase-AC
Nominal voltage	400V / 500V 3~, 50 Hz
Nominal current	28A / 23A
Motor nominal power	9 kW
Nominal speed	2830 1/min

Weight	87 kg without cable
Degree of protection	DIN IP68
Thread connection	R 4 ½" external thread R 3", R 4", R 6" BSP 2 ½", BSP 3", BSP 4", BSP 6" NPT 3", NPT 4", NPT 6"
Coupling	Storz A, Storz B, Storz F
Hose connection	ø110 mm

Material specification:

Casing	Aluminium alloy	3.2381
Impeller	Stainless steel	1.4027
Diffuser	Stainless steel	1.4027
Shaft	Stainless steel	1.4313
Suction bracket	Rubber	NBR
Inlet strainer	Aluminium alloy	3.2381
Shaft sealing	Dual mechanical seal	

Electrical connection:

- 20 m rubber-jacket cable with phase reversing connector plug
- alternatively with motor protection connector plug or with motor protection connector plug and float switch

special design on request

Characteristic curve:

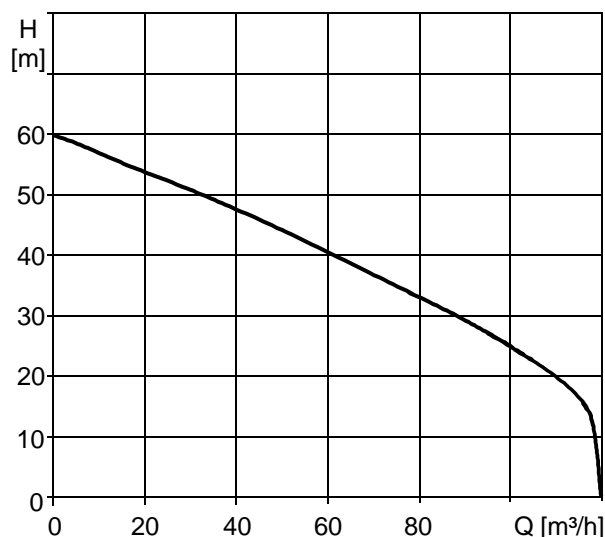

Delivery data:

Q [m ³ /h]	0	20	40	60	80	100	110	120
Q [l/s]	0	5.6	11,1	16.7	22.2	27.8	30.6	33.3
H [m]	60	53	47	40	33	26	21	0

Main dimensions:

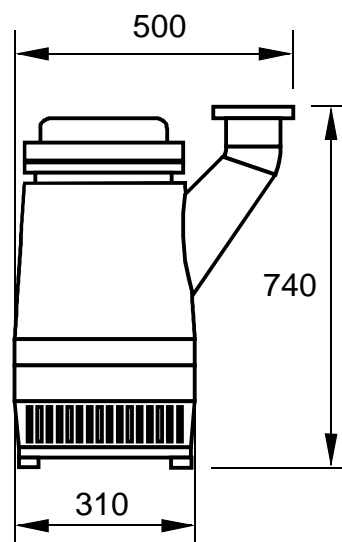

Subject to alterations