

PRORIL

50 Hz

Designed for light weight, excellent performance, low energy consumption, and easy maintenance, PRORIL submersible handy pumps serve a wide range of pumping applications on utility, construction, industrial, and municipal job sites.

Handy and Residue Pump

SMART LITE 400

Handy Pump



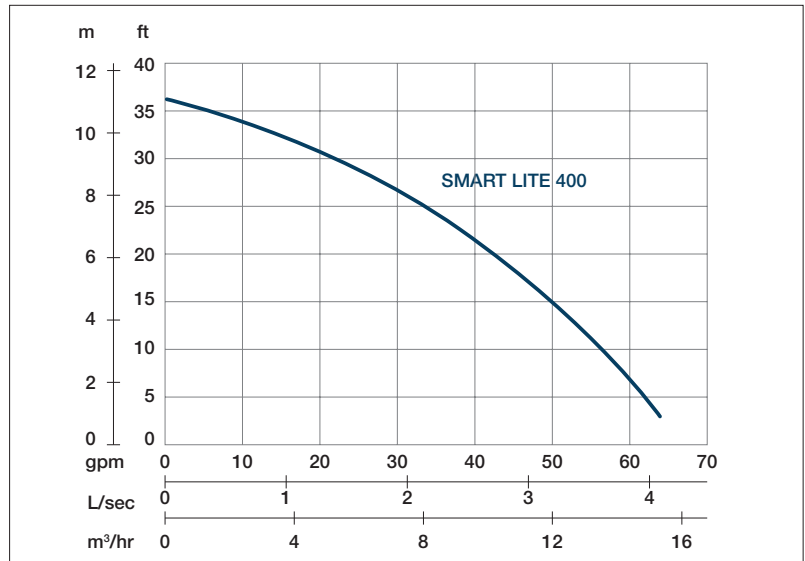

Shaft Speed : 2850 rpm

Outlet : 50mm, 2in

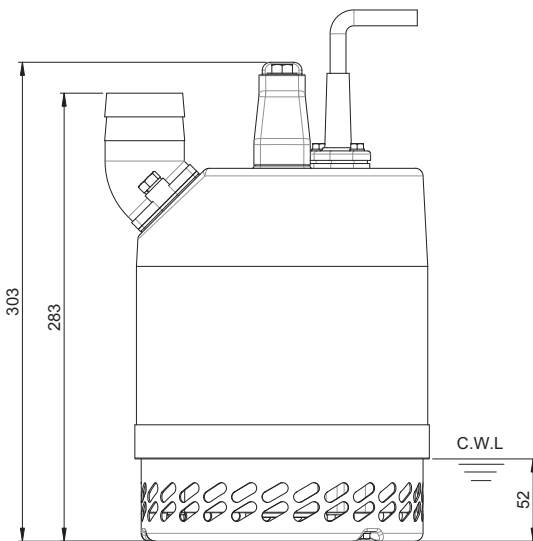
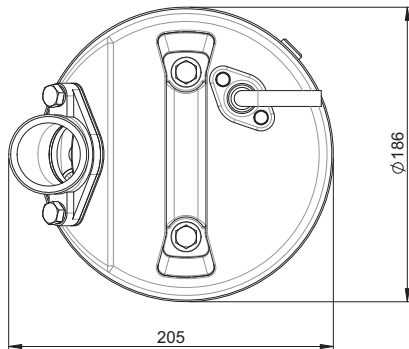

Weight : 10.5kg / 23 lbs

OUTPUT	HEAD	FLOW
0.4 kW	Rated : 7m, 23ft	Rated : 2 l/s, 37 gpm
0.5 HP	Max : 11m, 36ft	Max : 4 l/s, 63 gpm

Pump Type	Electric Submersible Pumps	
	1-Phase, 3-Phase	
Motor	Type	Induction Motor
	Poles	2 Pole
	Insulation	Class F
	Protector	Miniature Thermal Protector
	Starter	1-Phase • Capacitor-Run, 3-Phase • D.O.L
Lubricant	Food Grade (ISO VG32)	
Impeller Type	Semi-Vortex	
Shaft Seal	Double Mechanical Seal	
	Silicon Carbide VS Ceramic / Carbon	
Bearings	C3 Shielded ball bearings	
Cable	H07RNF	
	Length: 10m (33ft) or longer upon request.	
Materials	Pump Casing	Gray Iron
	Impeller	Urethane Rubber
	Motor Frame	Aluminum
	Motor Shaft	Stainless Steel
	Outer Cover	Aluminum
	Strainer	Carbon Steel
Max. Liquid Temperature	104°F (40°C)	
Max. Submersion Depth	66ft (20m)	
pH Range	pH 5 - pH 8	