

PRORIL

50 Hz

Designed for continuous operations, excellent performance and easy maintenance, PRORIL Tank series pumps have proven their reliability and durability in demanding areas like construction, mining, tunneling, quarries, industries and rental applications.

Dewatering Pump

TANK 455

High Chrome Dewatering Pump



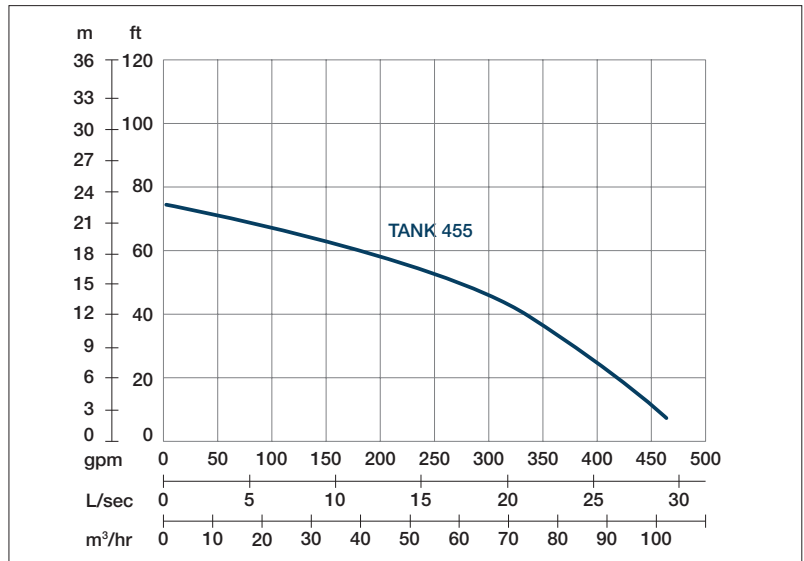

Shaft Speed : 2850 rpm

Outlet : 100mm, 4in

| OUTPUT | HEAD | FLOW |
|--------|-------------------|-------------------------|
| 5.5 kW | Rated : 15m, 49ft | Rated : 17 l/s, 264 gpm |
| 7.5 HP | Max : 22.5m, 74ft | Max : 29 l/s, 462 gpm |

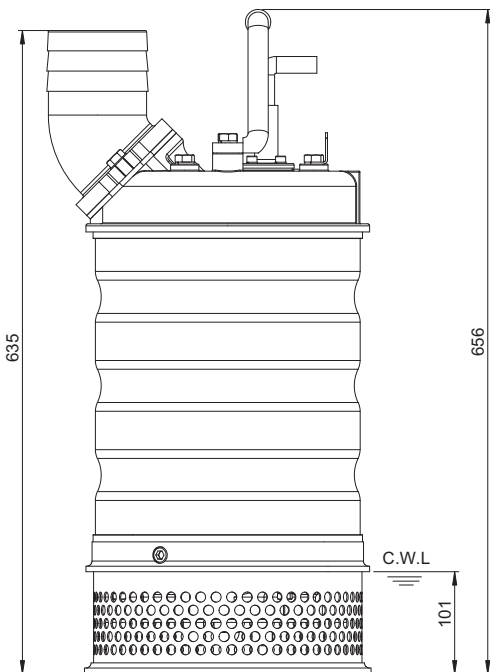
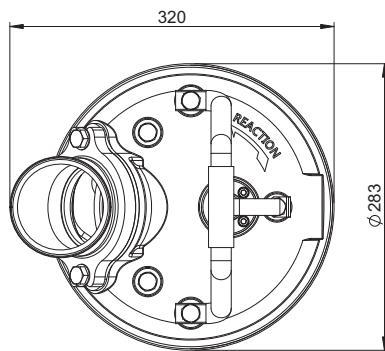

Weight : 60kg / 132 lbs

| | | |
|-------------------------|--|--------------------------|
| Pump Type | Electric Submersible Pumps | |
| | 3-Phase | |
| Motor | Type | Induction Motor |
| | Poles | 2 Pole |
| | Insulation | Class F |
| | Protector | Circle Thermal Protector |
| | Starter | D.O.L. |
| Lubricant | Food Grade (ISO VG32) | |
| Impeller Type | Opened | |
| Shaft Seal | Double Mechanical Seal | |
| | Silicon Carbide VS Ceramic / Carbon | |
| Bearings | C3 Shielded ball bearings | |
| Cable | H07BQF | |
| | Length: 20m (66ft) or longer upon request. | |
| Materials | Pump Casing | Gray Iron |
| | Impeller | Chromium Iron |
| | Motor Frame | Stainless Steel |
| | Motor Shaft | Stainless Steel |
| | Strainer | Stainless Steel |
| Max. Liquid Temperature | 104°F (40°C) | |
| Max. Submersion Depth | 66ft (20m) | |
| pH Range | pH 5 - pH 8 | |